

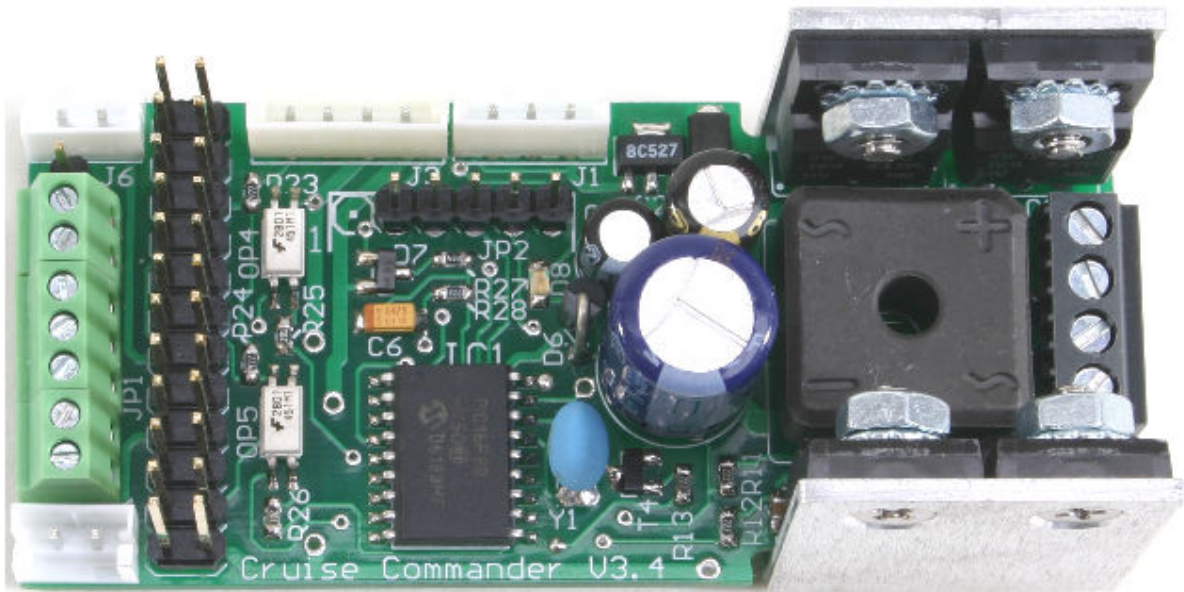

Cruise Commander 4.1

Instruction Manual



Revised: March, 2010

Cruise Commander

TMCC Compatible DC Cruise Command Upgrade Board

Overview

The patented Cruise Commander with SMS* Technology™ is a breakthrough in cruise control technology for 3-rail. The Cruise Commander Product line uses motor commutation and back-EMF to monitor the speed of the motor(s) attached instead of an external tachometer sensor. This method of motor control is easier to install than attaching an optical tachometer and timing tapes, and does not require a flywheel on the motor. With the Cruise Commander product installed, the performance of the locomotive will be greatly enhanced.

The Cruise Commander Product line has a lash-up feature, referred to as “nudge mode”. This mode allows a person to match the locomotives in a lash-up. Once the speeds are matched, they dynamically adjust with throttle position. The “nudge” settings are saved for future operating sessions; however they may be easily reset.

The Cruise Commander is capable of operating in 32 speed step mode for speed profile compatibility with most existing engines. The default setting for the Cruise Commander is 100 speed steps. The Cruise Commander uses the sound system to indicate configuration changes by blowing the whistle/horn for acknowledgement.

SMS* - Speed Management System

Enhanced Features

- Simple “Tach-Less” operation
- Same footprint and wiring as the AC/DC Commander
- Operates in command and conventional modes
- Single or Dual DC motor capability (8 amps peak)
- CAB-1™ selectable 32 or 100(default) speed steps
- Coil Couplers, Smoke, Strobe / Cab / Marker Lamp supported
- Uses Lionel R2LC to be fully compliant with TMCC standards.

Full Functions

Available in an 8 Amp DC motor version, additionally connecting Front and Rear Coupler, Front and Rear headlights, and Smoke or Strobe light outputs.

Small Footprint

2.75” L x 1.25” W x 1.15” H footprint including the heavy-duty heat sink

Included with Board

Antenna, hook-up wires, P/R switch, wire ties, mounting hardware

Cruise Commander Connector Pin Designations

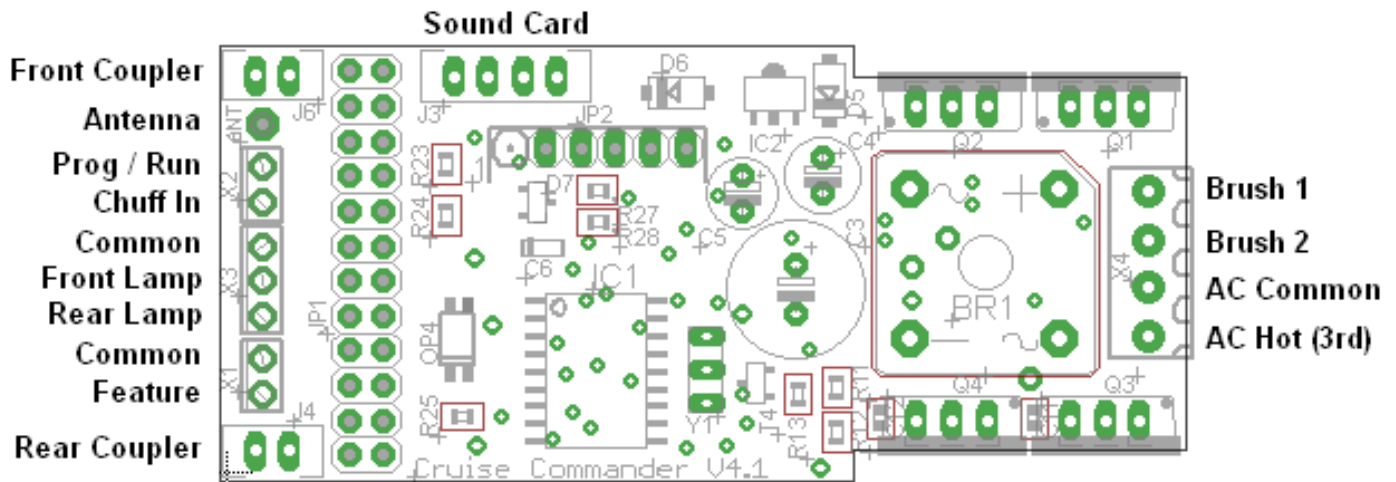

Installation Overview

Trim the wires that go into the mini screw terminal strip to prevent stray strands of wire. Be sure that the screws in the mini terminals are turned counter-clockwise to open, before wiring. Do not over tighten terminal screws when attaching the wires.

The PROGRAM / RUN switch should be positioned in a convenient location in the chassis. If the engine currently has a reverse lockout switch it can be used in place of the included switch. The switch is used to configure the receiver using the Program mode or Run mode. The switch is in the RUN position when it is open (with the slide lever over the unused terminals) and in Program when in the closed position.

If no convenient chassis holes exist for mounting the board, locate the board in the most optimum location, checking the clearance of the shell, mark its position, and drill a hole for a #6 screw in the chassis to mate with the center hole on the heatsink. Additional mounting holes are provided. To use one of these you will need to purchase a #6 self-tapping screw.

Be absolutely certain that the mounting screws do not protrude far enough through the heatsink to interfere with the circuit board. If necessary, add small washers to reduce the length that the screws extend beyond the heatsink. Do not over-tighten the screw in the aluminum heatsink.

Locate a suitable mounting location for the Cruise Commander. Be sure the shell will fit without obstruction. If you plan to add RailSounds or Sound Commander or keep the horn present in the low cost engines, be certain there is room for everything before drilling the mounting hole.

Installation

- Connections to the power and motor(s) should be made first. Be sure to get the HOT and COMMON identified correctly. Do not install any caps across the motor brushes. Do not try to figure out the correct motor polarity; simply reverse them later if the loco does not go the expected direction in the checkout process.
- Connections to the lighting, coil couplers, features (smoke shown), and program / run switch may be wired after the power and motors are wired. The following diagram shows the recommended connections. The smoke unit could be a strobe or cab light, based on the feature selection code.

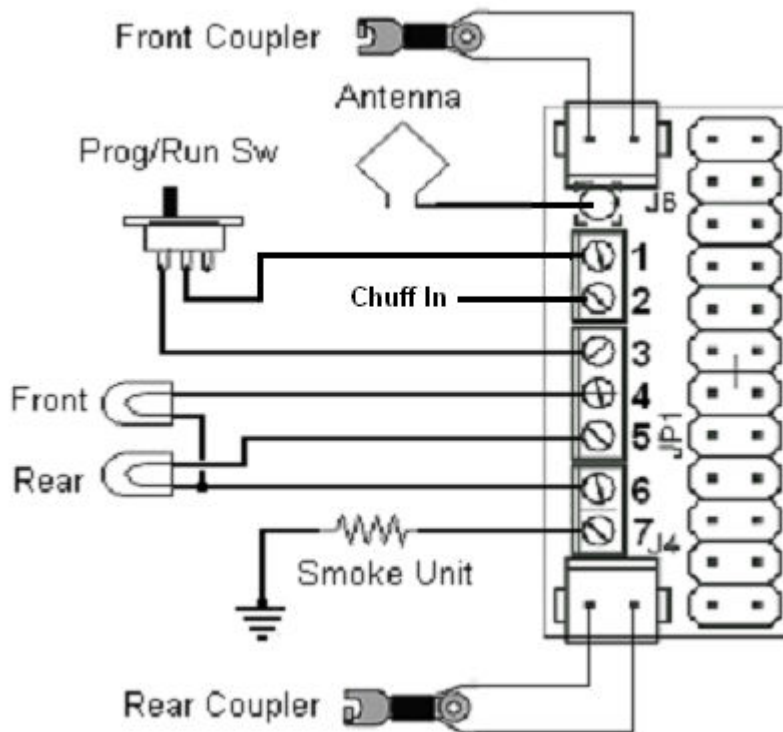

Note: There are two (2) commons on the card marked “com” on pins 3 and 6. These are electrically the same. Do NOT return the smoke unit common to the Cruise commander; attach to the chassis instead. When the feature pin (7) is a strobe or cab light, the return on these may be attached to pin 6 (or 3).

- The antenna should be plugged into the single pin connector between J6 (front coupler) and the screw terminal row pin 1. A wire for the antenna is included, and has an appropriate connector to mate with the ANT pin. It is suggested to tack this wire in the roof of the shell with a glue gun. The wire is 11” long, and should hang down about 4 inches below the shell to provide a reasonable length for access and ease of shell installation.

R2LC Installation

- Double check all wiring, and then install the R2LC receiver board onto the Cruise Commander board as shown below. Use **caution** not to miss by one pin pair to either side, as this will certainly damage the components on both cards.

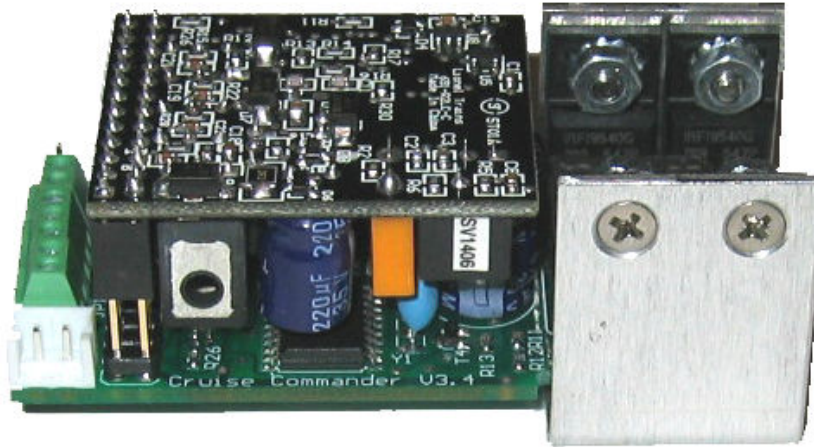

Speed Step Selection

The default speed step selection is 100 as shipped. The 100 speed steps are linear. The 100 speed steps start at a lower threshold, thus the motor is operating at a lower initial voltage with fine adjustment as the throttle is advanced. The momentum and stall features are not applicable, and do not operate.

To switch Speed Steps do the following:

Activate 32 Speed Steps: AUX1 + 0 + AUX1 + 0 + BRAKE

Activate 100 Speed Steps: AUX1 + 0 + AUX1 + 0 + BOOST

Note: The speed step selection is stored until changed, and survives power cycling.

Motor Type Selection

The Cruise Commander requires you to set the motor type. Motors are classified as small or large. Selecting the wrong motor size won't hurt anything, but operation is best when matched. The default motor type is "large motor" for the Cruise Commander.

To switch Motor Type do the following:

Activate Small Motor: AUX1 + 0 + AUX1 + 1

Activate Large Motor: AUX1 + 0 + AUX1 + 2

Note: The motor type selection is stored until changed, and survives power cycling.

Cruise On/OFF Selection

The Cruise feature may be turned on or off. This setting is stored and affects command and conventional mode operation.

To turn the Cruise OFF or ON, do the following:

Cruise Off: AUX1 + 0 + AUX1 + BRAKE + 7 + BRAKE

Cruise On: AUX1 + 0 + AUX1 + BRAKE + 9 + BRAKE

Note: The cruise off/on selection is stored until changed, and survives power cycling.

“Nudge Mode” Operation

The Cruise Commander has a bit of “play” to allow locos to operate in a lash-up. At times the “play” is not optimal, so it is possible to match locos a bit closer with the “nudge” mode feature. Remember to lash-up only very similar locos and that it is a requirement that the gear ratios match.

Simply try the locos together in a lash-up at slow speeds. If they buck each other, use the Cruise Commander “nudge” mode to try to match the locos a bit closer. Nudge mode basically increases the slower loco to match the speed profile of the faster loco. Although similar to a “stall” setting, the nudge mode is a bit more complex as it calculates the speed profile dynamically to hold the locos in sync throughout the throttle range.

First create a “TRain” with the Cab-1. Once the locos are operating in TRain mode do the following:

- Test run the locos (not coupled) to find the slower loco
- Place the slower loco behind the faster one
- Get them moving as a train, around 10 speed steps on the throttle
- Select the **slower** loco ENG ID
- Press AUX2 4 times, with a 1 second pause between each press
- The lights should blink off twice, confirming the loco to be “nudged”
- Use the Boost and Brake keys to adjust the slower loco to match the faster one
- Press “HORN” to lock the setting in the slower loco.
- Aux1 will cancel the setting.
- Couple the locos together and run as TRain.

To summarize:

Select: Slower Engine ID

Activate: AUX2 + AUX2 + AUX2 + AUX2

Nudge: BOOST to speed up, Brake to slow down

Save: Horn

To clear the nudge settings, select the speed step (32 or 100) on the “nudged” loco.

Note: the “nudge” selection is stored until changed, and survives power cycling.

Setting the R2LC ID and feature code

Setting the engine ID Number:

The R2LC Receiver comes with its engine ID set to ENG '1'. To change the engine ID, follow this procedure.

1. Make sure the Command Base is connected to the track
2. Set the engine PROGRAM / RUN switch to "PROGRAM"
3. Place the engine on the track and apply power
4. On the CAB-1, press [ENG] then the number (1 - 99) for the engine desired
5. Press [SET] (the engine ID is saved until you need to change it again)
6. Press [AUX1] [n], where n = the engine feature code (this must be done!)
7. Remove power from the track and place the switch back into the 'RUN' Position

Feature Code information:

The R2LC receiver module can be programmed to operate different features for different engines. Use only codes "4" through "8" for proper operation.

Code	Engine Type	Feature Terminal
0	Steam w/ Signal sounds	Smoke Unit
1	Diesel w/ Signal sounds	Strobe Light
2	Diesel w/ Signal sounds	Cab / Marker Light
4	Steam w/ Rail sounds	Smoke Unit
5	Diesel w/ Rail sounds	Strobe Light
6	Diesel w/ Rail sounds	Cab / Marker Light
8	Diesel w/ Rail sounds	Smoke Unit

Why is it necessary to set the Feature Code?

The Cruise Commander uses the serial data from the R2LC receiver to detect the throttle settings. This serial data signal is dependent on the feature code. If this is not properly set, the loco will not respond to throttle commands and may even enter into conventional mode and rocket down the rails! Additionally, features like the smoke unit will not operate until the feature code is set. It is always a good idea to know your loco feature codes for proper operation of smoke/strobe/cab/marker lighting effects. This is true of your entire TMCC loco stable.

When running in Conventional mode:

Cycling of engine direction can be overridden by placing the programming switch in the 'PROGRAM' position. This will lock the engine direction to the last operating direction. You must replace the switch back to the 'RUN' position if you wish to run the engine in Command mode.

TMCC Antenna Examples for Steamers

In the TMCC environment an antenna is a requirement. The best place for an antenna is on the underside of the shell roof. However, this works only as long as the shell is plastic. When the shell is die-cast or brass, the antenna is a bit more complicated. Some tenders have a plastic shell even though the loco is die-cast or brass and this provides an opportunity to place the antenna there.

A time-honored method to construct the antenna when the loco and tender are die-cast or brass is to use the tender shell for the antenna. This requires complete isolation of the tender shell from the tender chassis. After isolating the chassis, nylon screws are used to reattach the shell. Attaching the antenna wire to the shell may even involve drilling a hole in which to attach the wire. Kapton™ tape (used below) is preferred over electrical tape for insulation. An example of a tender chassis that is isolated from the shell is shown below:

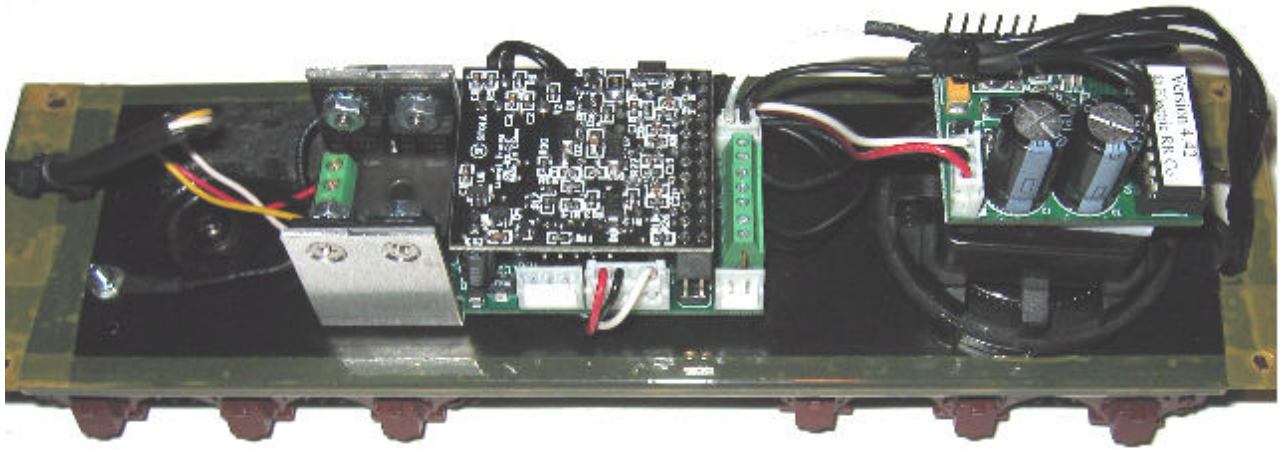

On some locos that have die-cast or brass tender shells, the coal load may be plastic. In this case looping the antenna wire under the plastic coal load works great. Use hot glue to hold the antenna in place.

The plastic coal load construction method is used on some K-Line and Williams locomotive tenders.

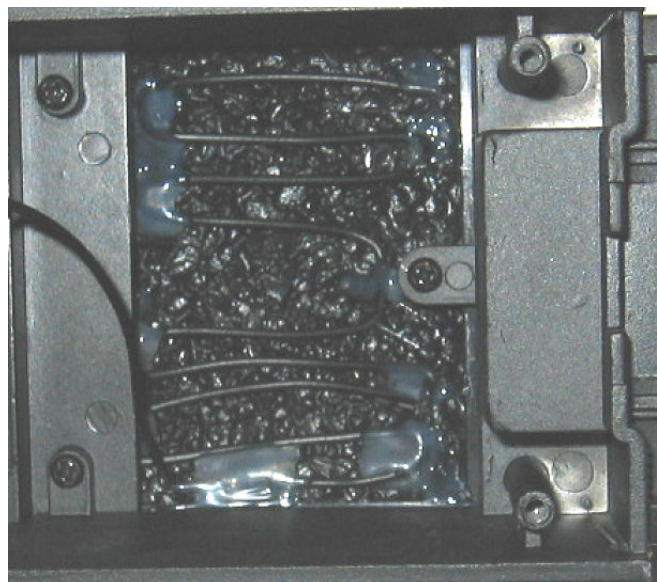

Limited Warranty

The Electric Railroad Company warrants to the original consumer purchaser that this product will be free of defects in materials and workmanship for a period of 90 days from the date of original purchase. This warranty does not cover service, repair, or replacement to correct any damage caused by improper installation, improper connection, external electrical fault, accident, disaster, misuse, abuse, or modifications to the product. All other express or implied warranties, including the implied warranty of merchantability and fitness for a particular purpose, are hereby disclaimed. If this product is not in good working order as warranted, the sole and exclusive remedy shall be repair or replacement. In no event shall The Electric Railroad Company, or any dealer, distributor, or authorized installation and/or repair service provider be liable for any damages in excess of the purchase price of the product. This limitation applies to damages of any kind, including but not limited to, direct or indirect damages, lost profits, lost savings or other special, incidental, exemplary or consequential damages whether for breach of contract, tort or otherwise, or whether arising out of the use of or inability to use the product, even if The Electric Railroad Company, or any dealer, distributor, or service provider has been advised of the possibility of such damages or any claim by any other party. Some states do not allow the exclusion or limitation of incidental or consequential damages so the above limitation or exclusion may not apply to you. During this warranty period, the product will either be repaired or replaced (at our option) without charge to the purchaser, when returned either to the dealer with proof of the date of purchase or directly to The Electric Railroad Company when returned prepaid and insured with proof of date of purchase. Some states do not allow limitations on how long an implied warranty lasts, so such limitations may not apply to you. This warranty gives you specific legal rights, and you may also have other rights, which vary from state to state.

Repairs

Each and every product is thoroughly tested before it is shipped. The likelihood that it is not working when it reaches you is very small. However, if after troubleshooting it yourself you cannot get it to work properly, contact us to help determine the problem.

Should your product ever need repair, return it postpaid directly to The Electric Railroad Company. If the product is within the warranty period, it will be repaired or replaced and returned to you free of charge. Units out of warranty will be repaired or replaced for a service charge of \$50.00 at our option.

Please email to support@electricrr.com for return authorization before returning any product.

Disclaimer

Improper installation or configuration of the Cruise Commander Board can cause overheating and fires! Since it is not possible to understand every installation, it is the consumer's responsibility to verify proper operation of the upgrade to prevent malfunction. If you are unsure of your install, please contact us first before taking any risks!

All manual contents are Copyright ©2006, The Electric Railroad Company, 2326 Walsh Avenue, Santa Clara, CA. TMCC, CAB-1, R2LC, SignalSounds, & RailSounds are registered trademarks of Lionel, LLC.