



AC Commander

Instruction Manual



Revised: October, 2008

AC Commander

TMCC Compatible AC Command Upgrade Board

Overview

The AC Commander with patented SMS* Technology™ is the perfect engine upgrade for those who desire more speed steps than the usual 32. The AC Commander is capable of operating in 32 speed step mode for speed profile compatibility with existing engines. When desired, the AC Commander can be switched to operate with 100 speed steps. The low-end speed control performance is noticeably improved in this mode of operation. Even AC motors can be set to "creep" down the rails!

SMS* - Speed Management System

Enhanced Features

- AC motor capability (8 amps)
- CAB-1™ selectable 32 (default) or 100 speed steps
- On-board micro-controller provides future enhancement capabilities
- Horn pulse output to control post-war and modern-era horns
- Splice free connections make installation simple and quick
- Uses Lionel R2LC to be fully compliant with TMCC standards.

Speed Selection

Activate 32 speed steps: AUX1 + 0 + AUX1 + 0 + BRAKE

Activate 100 speed steps: AUX1 + 0 + AUX1 + 0 + BOOST

Full Functions

Available in an 8 Amp AC motor version, additionally connecting Front and Rear Coupler, Front and Rear headlights, and Smoke or Strobe light outputs.

Small Footprint

2.75" L x 1.25" W x 1.15" H footprint including the heavy-duty heat sink. R2LC tucks neatly onto the provided connector supplying solid electrical and mechanical mounting.

Easy Installation

Uses miniature screw terminal connectors for wires, and specialized connectors to connect coil couplers and sound systems.

Included with Board

Antenna, hook-up wires, 1µf caps, lugs, P/R switch, wire ties, mounting hardware

Driver Board Connector Pin Designations

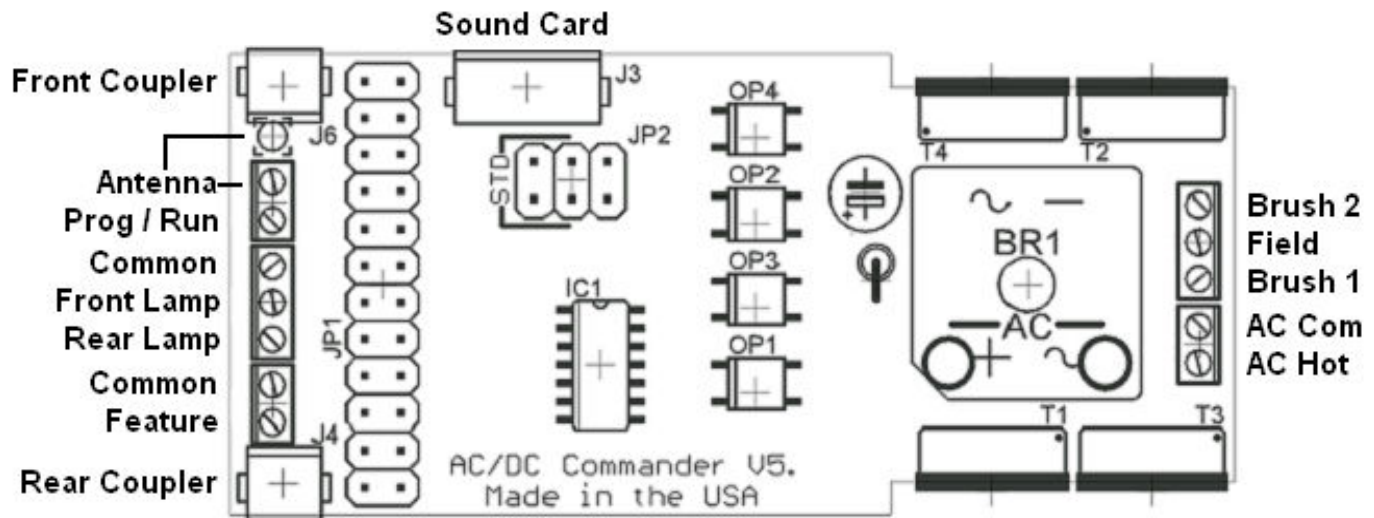

Installation Overview

Trim the wires that go into the mini screw terminal strip to prevent stray strands of wire. Before wiring, be sure that the screws in the mini terminals are turned counter-clockwise to open. Do not over-tighten terminal screws when attaching the wires.

The PROGRAM / RUN switch should be positioned in a convenient location in the chassis. If the engine currently has a reverse lockout switch it can be used in place of the included switch. The switch is used to configure the receiver using the Program mode or Run mode. The switch is in the RUN position when it is open (with the slide lever over the unused terminals) and in Program when in the closed position.

If no convenient chassis holes exist for mounting the board, place the board in the most optimum location, checking the clearance of the shell. Mark its position, and drill a hole for a #6 screw in the chassis to mate with the center hole on the heat-sink. Additional mounting holes are provided. To use one of these you will need to purchase a #6 self-tapping screw.

Be absolutely certain that mounting screws do not protrude far enough through the heatsink to interfere with the circuit board. If necessary, add small washers to reduce the length that the screws extend beyond the heatsink. Do not over-tighten the screw in the aluminum heatsink. For dual AC motors, it is advisable to add thermal conductive compound where the heatsink come in contact with the chassis.

Two lugs are included to attach the caps to the AC motor frame. This frame connection usually has one lug already, and is where you get the “common” to the AC Commander. Connecting to the chassis for “common” is not recommended.

Installation

- Locate a suitable mounting location for the AC commander. Be sure the shell will fit without obstruction. If you plan to add RailSounds or keep the horn present in low cost engines, be sure there is room for everything before drilling the mounting hole.
- Prepare the motor; adding the capacitors as shown below. Add ground lugs as needed to attach the capacitors. Bypass capacitors (included) are added across the motor brushes to suppress RF noise. On AC motors, these caps need to be attached from each brush to chassis at the motor.

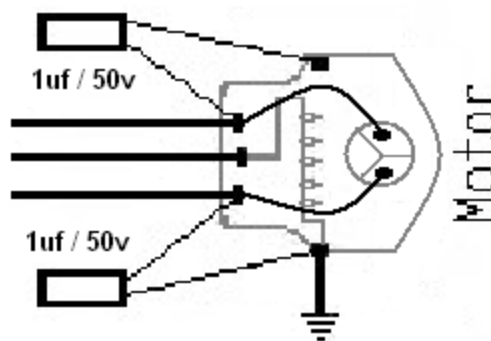

AC Motor with required bypass caps

- Wire the AC Commander to the motor. AC motor wiring is shown below. When finished, if the motor direction is not correct, simply reverse the yellow & blue wires.

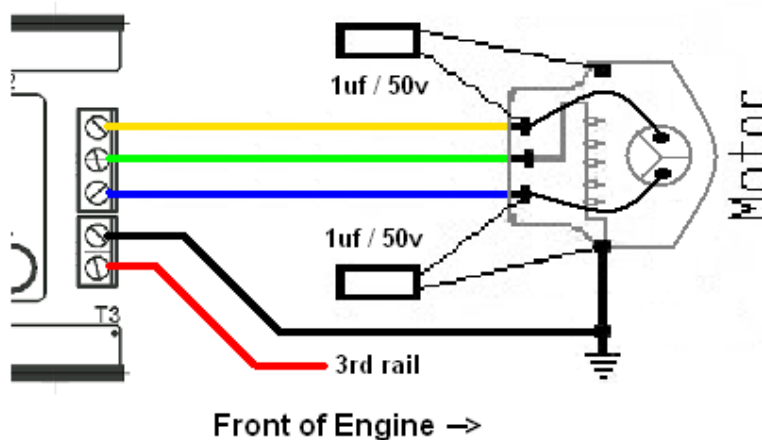

- Connections to the lighting, coil couplers, features (smoke shown), and program / run switch should be made now. The following diagram shows the recommended connections. The smoke unit could be a strobe or cab light, based on the feature selection code.

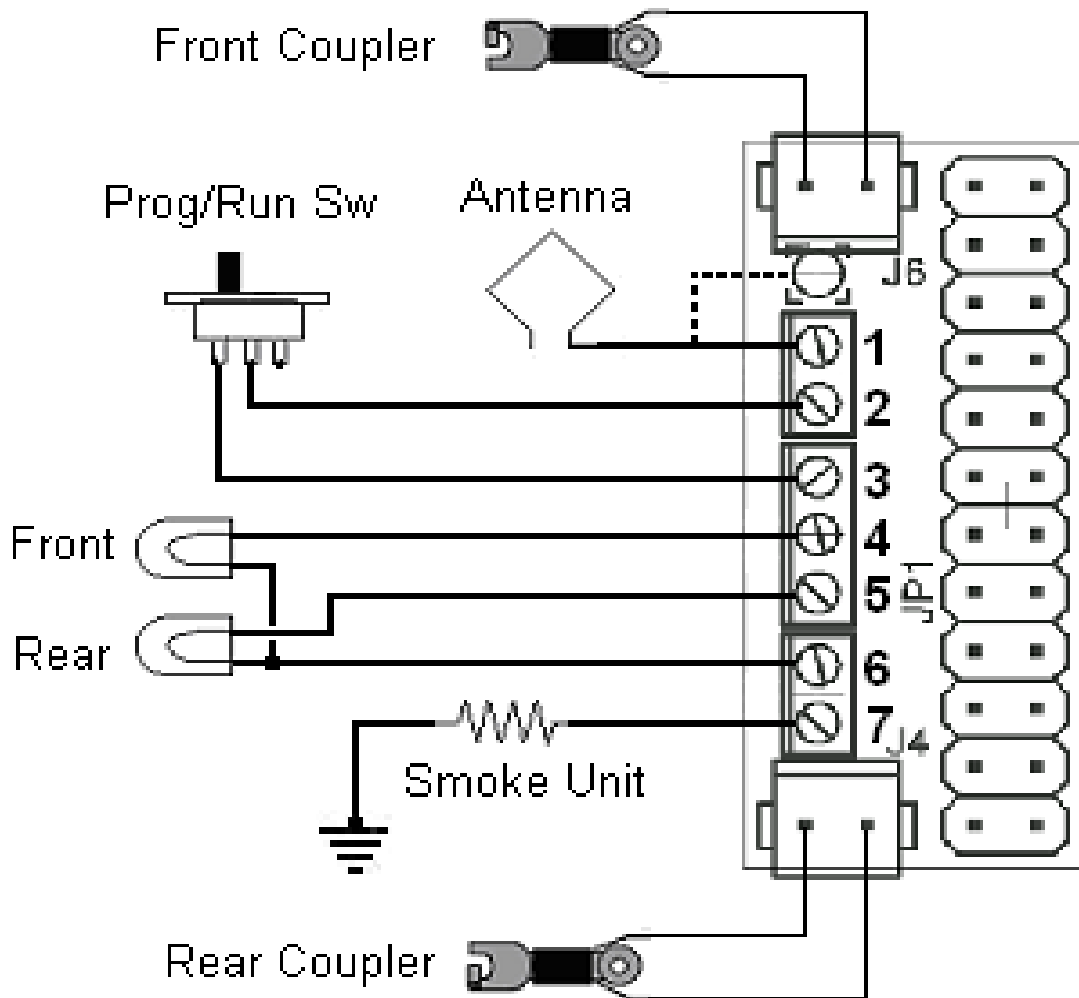

Note: There are two (2) commons on the card marked “com” on pins 3 and 6. These are electrically the same. Do not return the smoke unit common to the AC commander, attach to chassis instead. When the feature pin (7) is a strobe or cab light, the return on these may be attached to pin 6 (or 3).

- The antenna should be plugged into the single pin connector between J6 (front coupler) and the screw terminal row pin 1. If you wish, you may attach the wire in screw terminal #1, which is electrically the same as the ANT pin. A wire for the antenna is included, and has an appropriate connector to mate with the ANT pin. It is suggested to tack this wire in the roof of the shell with a glue gun. The wire is 11” long, and should hang down about 4 inches below the shell to provide a reasonable length for access and ease of shell installation.

R2LC Installation

- Double check all wiring, then install the R2LC receiver board onto the AC Commander board as shown below. Use **caution** not to miss by one pin pair to either side, as this will certainly damage the components on both cards.

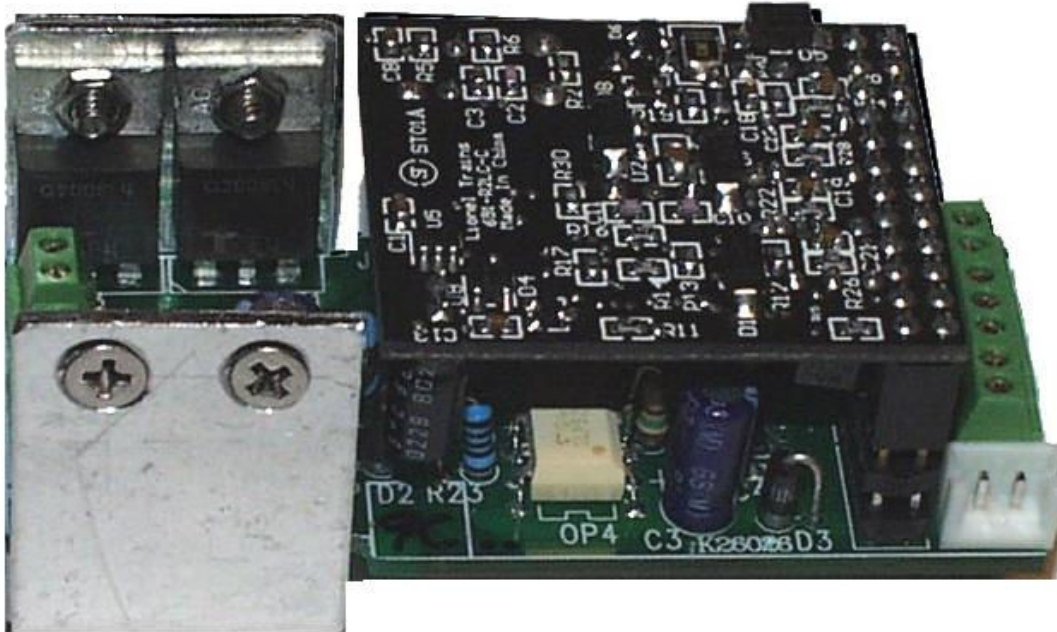

Speed Step Selection

The default speed step selection is 32 as shipped. This profile matches the default of the R2LC. This mode of operation is desirable when lashing up to engines that do not have the AC Commander installed.

The major advantage to the AC Commander is the ability to set 100 speed steps on the throttle. The 100-speed steps are linear. The speed steps start at a lower threshold, thus the motor is operating at a lower initial voltage with fine adjustment as the throttle is advanced. This greatly enhances the ability to control the engines. The momentum and stall features are not applicable to the 100 speed steps operation.

To switch speed steps do the following:

Activate 32 speed steps: AUX1 + 0 + AUX1 + 0 + BRAKE

Activate 100 speed steps: AUX1 + 0 + AUX1 + 0 + BOOST

The speed step selection is stored until changed, and survives power cycling.

Setting the R2LC ID and Feature Code

Setting the engine ID Number:

The R2LC Receiver comes with its engine ID set to ENG '1'. To change the engine ID, follow this procedure.

1. Make sure the Command Base is connected to the track
2. Set the engine PROGRAM / RUN switch to "PROGRAM"
3. Place the engine on the track and apply power
4. On the CAB-1, press [ENG] then the number (1 - 99) for the engine desired
5. Press [SET] (the engine ID is saved until you need to change it again)
6. Press [AUX1] [n], where n = the engine feature code (this must be done!)
7. Remove power from the track and place the switch back into the 'RUN' Position

Feature Code information:

The R2LC receiver module can be programmed to operate different features for different engines. Use only codes "4" through "8" for proper operation.

Code	Engine Type	Feature Terminal
0	Steam w/ Signal sounds	Smoke Unit
1	Diesel w/ Signal sounds	Strobe Light
2	Diesel w/ Signal sounds	Cab / Marker Light
4	Steam w/ Rail sounds	Smoke Unit
5	Diesel w/ Rail sounds	Strobe Light
6	Diesel w/ Rail sounds	Cab / Marker Light
8	Diesel w/ Rail sounds	Smoke Unit

Why is it necessary to set the Feature Code?

The Cruise Commander uses the serial data from the R2LC receiver to detect the throttle settings. This serial data signal is dependent on the feature code. If this is not properly set, the loco will not respond to throttle commands and may even enter into conventional mode and rocket down the rails! Additionally, features like the smoke unit will not operate until the feature code is set. It is always a good idea to know your loco feature codes for proper operation of smoke/strobe/cab/marker lighting effects. This is true of your entire TMCC loco stable.

When running in Conventional mode:

Cycling of engine direction can be overridden by placing the programming switch in the 'PROGRAM' position. This will lock the engine direction to the last operating direction. You must replace the switch back to the 'RUN' position if you wish to run the engine in Command mode.

TMCC Antenna Examples for Steamers

In the TMCC environment, an antenna is a requirement. The best place for an antenna is on the underside of the shell roof. This works as long as the shell is plastic. When the shell is die-cast or brass, the antenna is a bit more complicated. Some tenders have a plastic shell even though the loco is die-cast or brass, and this provides an opportunity to place the antenna there.

A time-honored method to construct the antenna when the loco and tender are die-cast or brass is to use the tender shell for the antenna. This requires complete isolation of the tender shell from the tender chassis. After isolating the chassis, nylon screws are used to reattach the shell. Attaching the antenna wire to the shell may even involve drilling a hole in which to attach the wire. Kapton™ tape (used below) is preferred over electrical tape for insulation. An example of a tender chassis that is isolated from the shell is shown below:

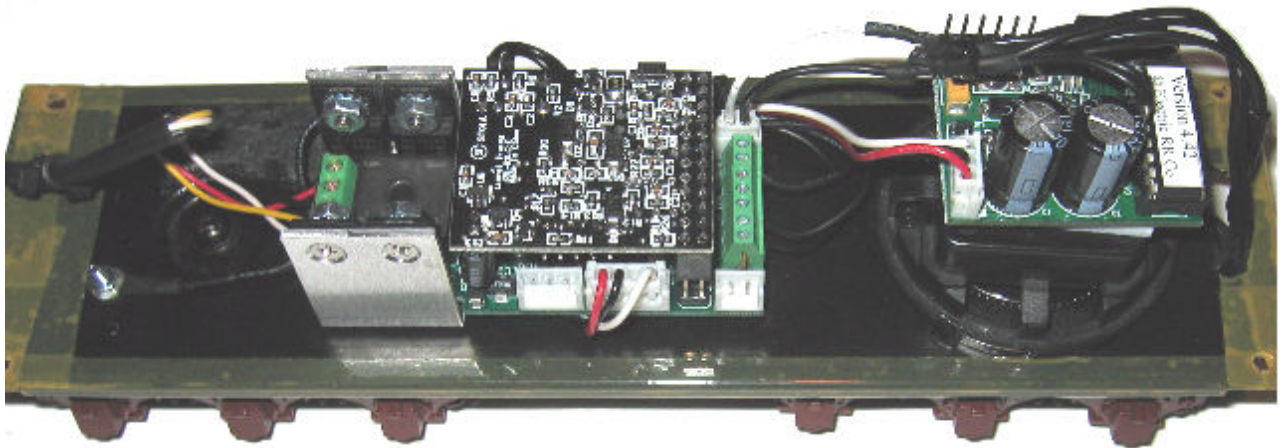

On some locos that have die-cast or brass tender shells the coal load may be plastic. In this case, looping the antenna wire under the plastic coal load works great. Use hot glue to hold the antenna in place.

The plastic coal load construction method is used on some K-Line and Williams locomotive tenders.

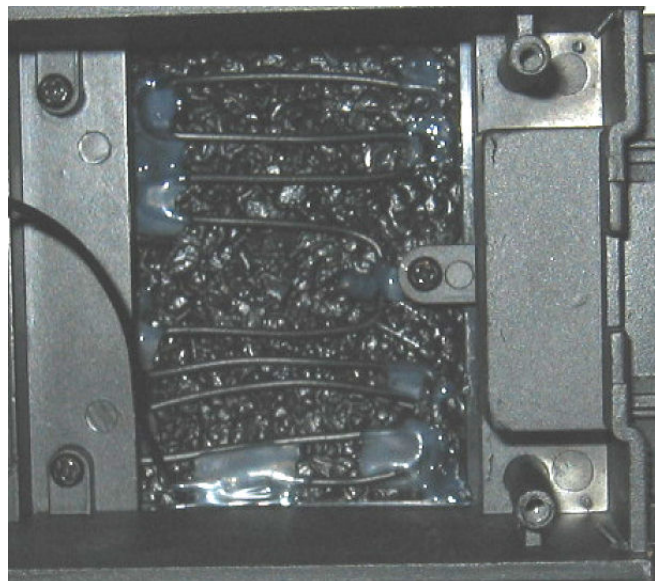

Optional Horn Control

The AC commander has a unique control signal available on the standard RailSounds connector. Typically this pin, #3, is not connected to any signal source. On the AC Commander, pin 3 generates a logic “high” when the “Horn” button is pressed on the Cab-1. Using this signal, various electronic horns, whistles, and post war whistles (with a small helper circuit) may be activated. Contact support@electricrr.com for your specific requirements and assistance.

Electronic Horn:

The Lionel electronic horns have changed very little over the lifetime of the product. These carry the part number: 6-00-8152-050. Shown below are 2 versions. While electrically the same, they look a bit different. To activate this horn, only a single wire from the AC Commander RailSounds pin 3 connection is required to the “trigger” point. Connect the wire to the trigger point attachment on the horn card.

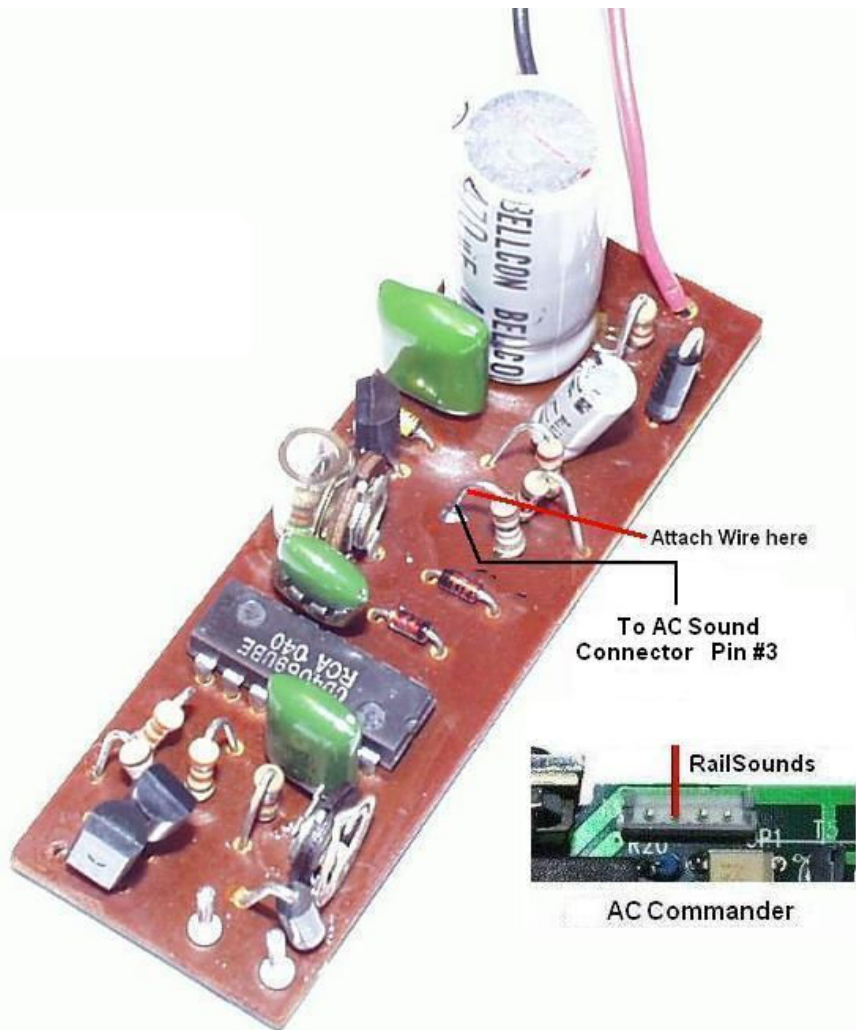

Older version of the Electronic Horn

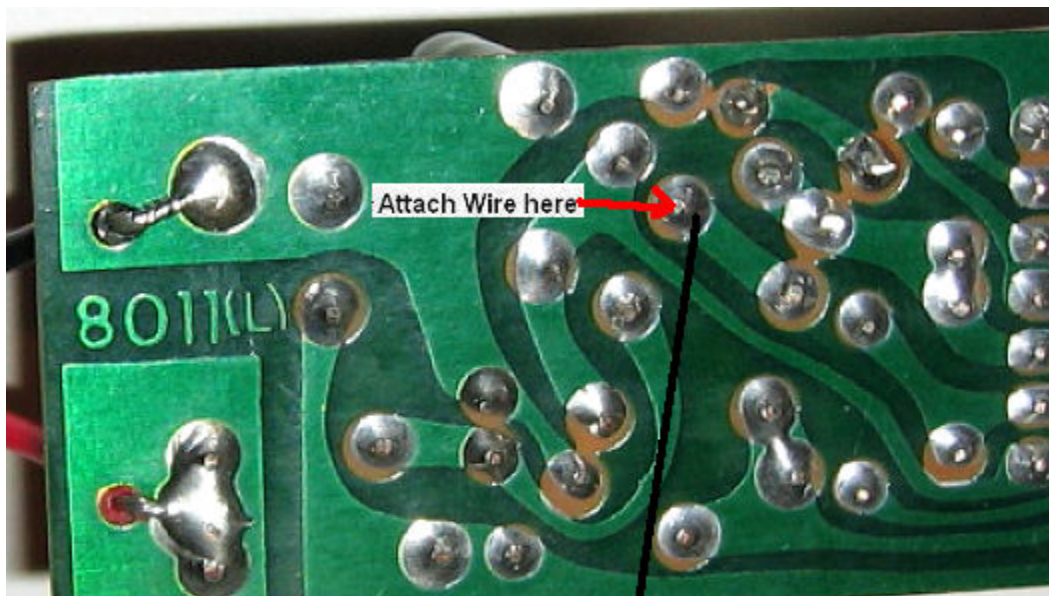
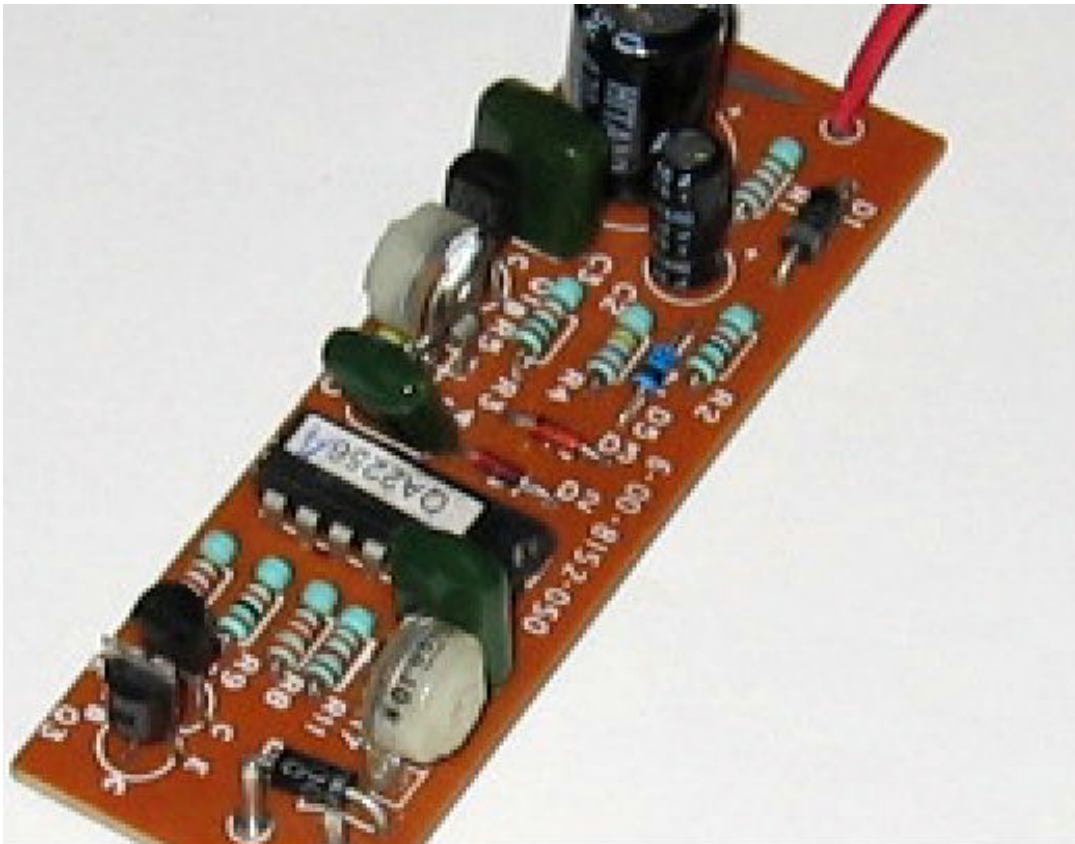

To AC Sound Connector
Pin #3

Newer version of the Electronic Horn

Electronic Whistle:

The modern-era whistle controller may be operated similarly as the electronic horns. Only a single wire from the AC Commander RailSounds pin 3 connection is required to the “trigger” point. A connector with a wire attached is provided in the kit. Connect the wire to the trigger point attachment on the whistle card as indicated below:

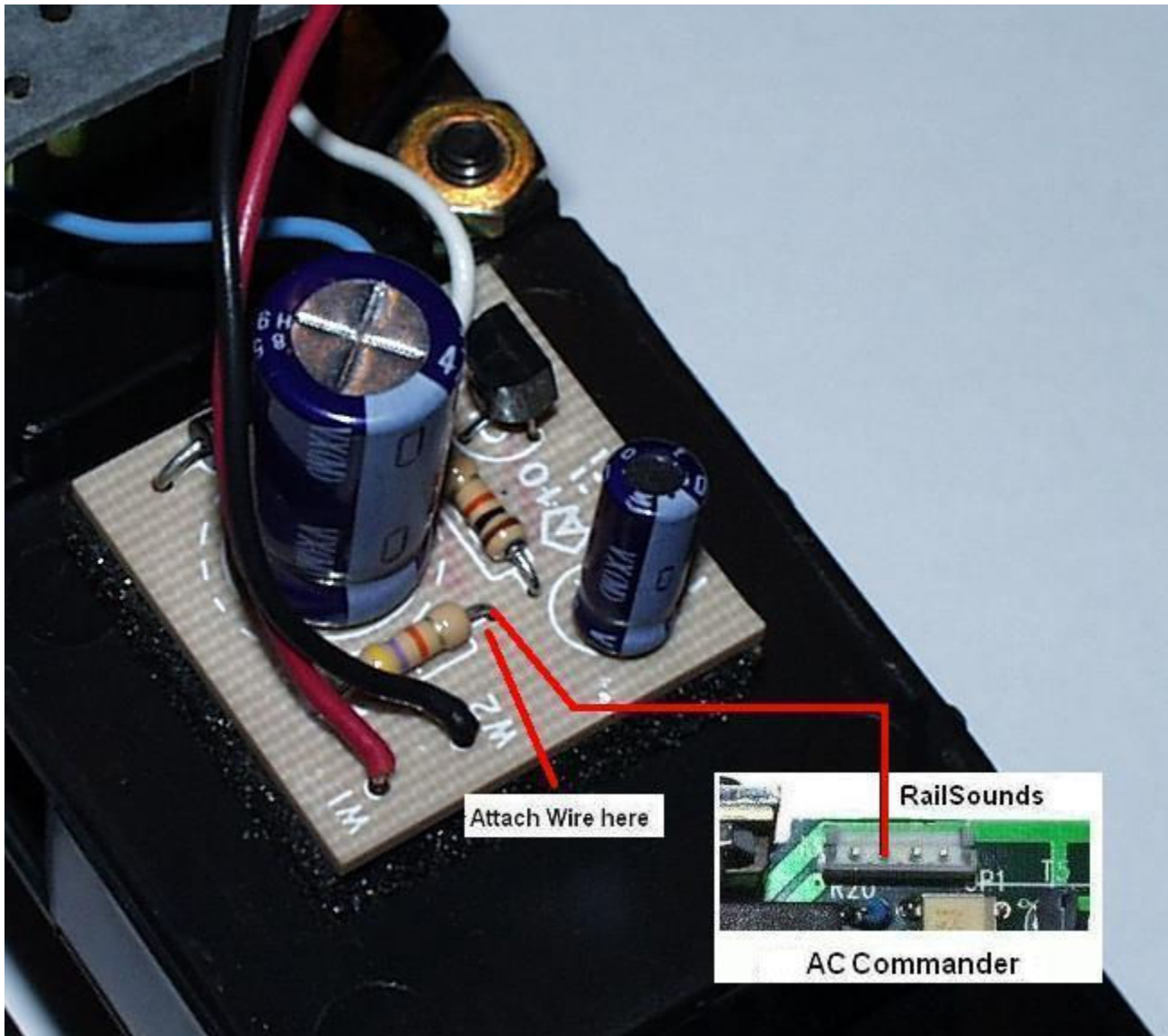

NOTE: Some modern-era whistle controllers will self-trigger at 18v track power. Try your tender at 18v before proceeding with any changes. Use **caution** if using the engine to supply power to the tender so as not to burn out your engine headlamps on the 18v track power! If you want to connect the tender to the track without the engine via clip leads, the tip of the connector from the tender goes to the center rail. If your tender whistles at 18v, please contact support@electricrr.com for help with the needed changes for these conversions.

Limited Warranty

The Electric Railroad Company warrants to the original consumer purchaser that this product will be free of defects in materials and workmanship for a period of 90 days from the date of original purchase. This warranty does not cover service, repair, or replacement to correct any damage caused by improper installation, improper connection, external electrical fault, accident, disaster, misuse, abuse, or modifications to the product. All other express or implied warranties, including the implied warranty of merchantability and fitness for a particular purpose, are hereby disclaimed. If this product is not in good working order as warranted, the sole and exclusive remedy shall be repair or replacement. In no event shall The Electric Railroad Company, or any dealer, distributor, or authorized installation and/or repair service provider be liable for any damages in excess of the purchase price of the product. This limitation applies to damages of any kind, including but not limited to, direct or indirect damages, lost profits, lost savings or other special, incidental, exemplary or consequential damages whether for breach of contract, tort or otherwise, or whether arising out of the use of or inability to use the product, even if The Electric Railroad Company, or any dealer, distributor, or service provider has been advised of the possibility of such damages or any claim by any other party. Some states do not allow the exclusion or limitation of incidental or consequential damages so the above limitation or exclusion may not apply to you. During this warranty period, the product will either be repaired or replaced (at our option) without charge to the purchaser, when returned either to the dealer with proof of the date of purchase or directly to The Electric Railroad Company when returned prepaid and insured with proof of date of purchase. Some states do not allow limitations on how long an implied warranty lasts, so such limitations may not apply to you. This warranty gives you specific legal rights, and you may also have other rights, which vary from state to state.

Repairs

Each and every product is thoroughly tested before it is shipped. The likelihood that it is not working when it reaches you is very small. However, if after troubleshooting it yourself you cannot get it to work properly, contact us to help determine the problem.

Should your product ever need repair, return it postpaid directly to The Electric Railroad Company. If the product is within the warranty period, it will be repaired or replaced and returned to you free of charge. Units out of warranty will be repaired or replaced for a service charge of \$30.00 at our option.

Please email to support@electricrr.com for return authorization before returning any product.

Disclaimer

Improper installation or configuration of the AC Commander Board can cause overheating and fires! Since it is not possible to understand every installation, it is the consumer's responsibility to verify proper operation of the upgrade to prevent malfunction. If you are unsure of your install, please contact us first before taking any risks!

All manual contents are Copyright ©2004, The Electric Railroad Company, 2326 Walsh Avenue, Santa Clara, CA. TMCC, CAB-1, R2LC, SignalSounds, and RailSounds are registered trademarks of Lionel, LLC.